

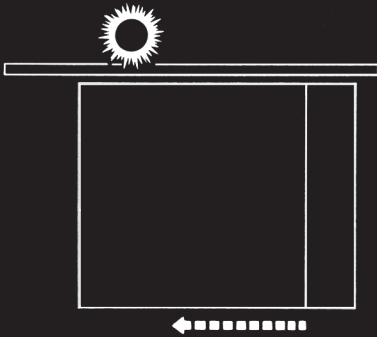

C R O W N  
I N D U S T R I A L  
O P E R A T O R S

Read  
This  
FIRST



**GENERAL  
INSTALLATION,  
OPERATION,  
MAINTENANCE,  
and PARTS MANUAL  
for your**

**Aut-o-door**

**1502-1 & 1502-2  
SWING DOOR- Heavy Duty  
OPERATORS**

Copyright © Crown Industrial Operators 2011

**Crown Industrial Operators**  
(Formerly manufactured by Richards-Wilcox)  
213 Michelle Court  
So. San Francisco, CA 94080  
Phone (650) 952-5150  
Fax (650) 873-1495  
website: [www.crown-industrial.com](http://www.crown-industrial.com)

**G-1001-R1**

## CONTENTS

PARAGRAPH		PAGE
1	INTRODUCTION .....	1
	A Purpose .....	1
	B Models Covered .....	1
	C Application .....	1
	D Description .....	1
2	INSTALLATION AND OPERATION .....	1
	A General .....	1
	Push and Pull Arm Assembly .....	2
	B Mounting the Operator .....	3
	C Wiring Operator and Controls .....	3
	D Start Up .....	3
	E Check Operation Motor .....	4
	F Setting Electric Clutch Resistance .....	5
	G Setting Run Timer .....	5
3	MAINTENANCE .....	5
	A General .....	5
4	PARTS .....	6
	A To Order Replacement Parts .....	6
	B Parts List .....	6&7
	WARRANTY .....	11

Note: We reserve the right to modify or change, without prior notice, any statements or information contained herein. If exact dimensions or specifications are required by the customer certified prints will be furnished without charge upon request to Crown Industrial. This manual covers standard catalogued operators only and does not cover special non-standard equipment.

## 1. INTRODUCTION

**A. PURPOSE:** This Crown Installation, Operation, Maintenance and Parts Manual has been developed to assist you in the installation, operation and maintenance of your electric operator and thus enable you to utilize it to its maximum efficiency.

**B. MODELS COVERED:** The manual covers current models 1502-1 & 1502-2 Operators.

**C. APPLICATION:** The Crown Industrial Model #1502 Swing Door Operators are intended for use on large interior industrial doors operated by trained personnel.

### D. DESCRIPTION:

The model 1502 operator consists of a 90 volt, DC permanent magnet gear motor, variable torque electric clutch, right angle worm gear and internal limit switches. The motor control is accomplished by means of an electronic control package. The motor controls are mounted in a remotely located control panel. The operator shall mount above the door on the lintel of the frame. Door connecting arms and door brackets are included. The operator mounting frame and cover shall

be prime coated ready for finish painting in the field. The supply voltage should be 120 volt AC, single phase. The control circuit will allow for two speed operation with the run and creep speeds independently adjustable.

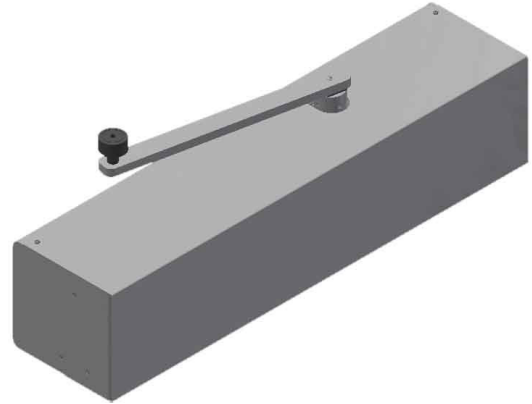

Figure 1. 1502 Left Hand Swing Door Operator

## 2. INSTALLATION AND OPERATION

### A. GENERAL

The Crown 1502 Electric Door Operator has been designed primarily for commercial and industrial installations where the operator has to withstand constant hard use. To ensure correct installation and proper operation of the operator and associated hardware, the following instructions are given:

(1) **SHIPMENT CHECK:** Included with the installation packet is a copy of the packing slip for the components supplied with the order. Compare the components received with the packing slip to insure that all equipment is complete.

(2) **REVIEW INSTALLATION DRAWINGS:** The installation drawings show the layout of the door, template drilling for the door and jamb, and general terms used to describe the components. Review the drawings to familiarize yourself with the equipment.

(3) **CHECK THE DOORS:** Prior to installing the operator, confirm the doors are properly hung. 95% of all door operator trouble is caused by doors not swinging free of the floor and lintel. It is also very important that all hinge pins are properly aligned and there is no hinge binding.

### (4) PREPARING THE DOOR AND LINTEL:

The door operators are handed (left and right) and are supplied as push or pull to open (Refer to Figure 2 Operator Handing). Ensure proper backing and support are available in the lintel and the door to receive the operator and connecting arm. Remove the electric operator from crate. Choose the appropriate drilling template. Prepare the lintel for the operator.

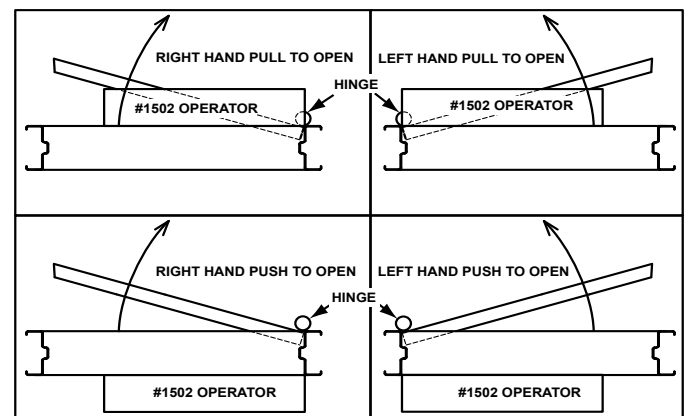
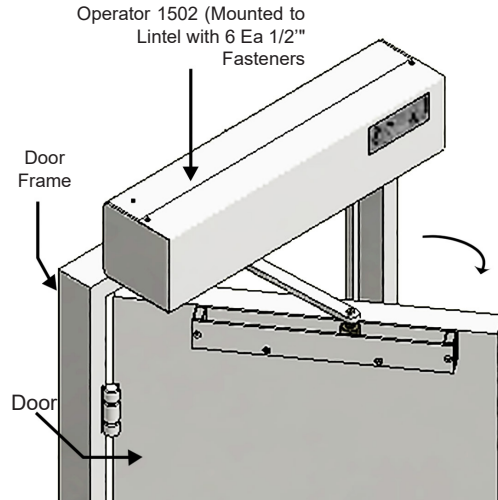
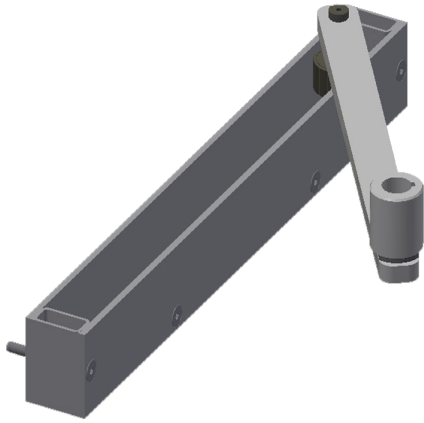

Figure 2. Operator Handing

# PUSH AND PULL ARM ASSEMBLY

Operator 1502 is engineered to support push, pull to open doors both left and right directions.

## #1502-PULLLO

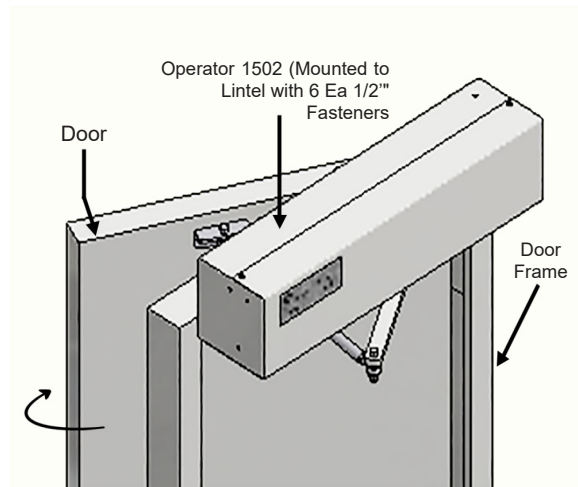
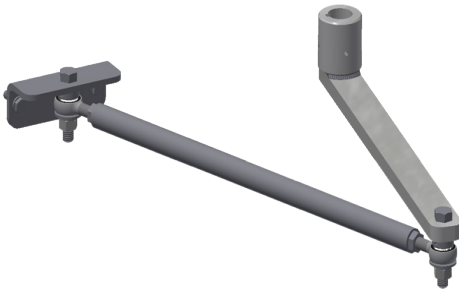

**Figure 3. 1502-PULLLO Operator Assembly**

The arm has a roller attached to the end, guided by a track that is mounted on the pull side of the door. The arm is directly mounted to the operator drive shaft.

Note: For pull to open applications the operator is mounted **OPPOSITE** of the door hinges.

## #1502-PUSHO



**Figure 4. 1502-PUSHO Operator Assembly**

The angle bracket is mounted to the face of the door with fasteners, while the other end mounts directly to the operator drive shaft.

Note: For push to open applications the operator is mounted **OPPOSITE** of the door hinges.

## B. MOUNTING THE OPERATOR

Mount the operator according to the chosen illustration on page 2. The operator must be installed level. With the door in the closed position drill the door to receive the door bracket (Note: fasteners are supplied by others). Attach the arms from the operator to the door bracket. Manually swing door open and closed ensuring both the door and operator function freely.

## C. WIRING OPERATOR AND CONTROLS:

(1) No. 1502 Electric Operators are intended for applications with motor branch circuits that have voltage and current characteristics to meet the operators' ratings. Branch circuit, branch circuit disconnecting means, and branch circuit over current protection are to be properly sized in respect to the operators' horsepower rating.

**WARNING: Insure operator branch circuit is disconnected from power source when installing, adjusting or servicing operator.**

(2) **Be sure all power is off.** Wire the electric operator and controls according to the wiring diagrams provided in the installation packet.

## D. START-UP:

(1) Confirm all wires are correctly connected to terminals. Reference wiring schematic provided in the installation packet.

(2) LIMIT SWITCH ADJUSTMENT:

- (a) **Disconnect the Electrical Power Supply to the Operator Control Box.**
- (b) Unscrew limit switch cover and expose assembly.

### Reference **Figure 3. Rotary Cam Limit Switch Assembly.**

Note: For right hand pull to open or left hand push to open operators.

- (a) **LSO = Limit Switch Open (Wired Normally Closed)**  
This limit shuts off the electric operator when the door reaches the full open position. (Light on PLC turns **OFF** when activated)
- (b) **LSC = Limit Switch Close (Wired Normally Closed)**  
This limit shuts off the operator when the door has reaches the full closed position. (Light on PLC turns **OFF** when activated)
- (c) **LSCO = Limit Switch Creep Open (Wired Normally Open)**  
This limit activates the creep mode during the end of open cycle. When the limit switch is actuated the door travels in the open direction at a reduced speed. (Light on PLC turns **ON** when activated)
- (d) **LSCC = Limit Switch Creep Close (Wired Normally Open)**  
This limit activates the creep mode during the closing cycle. When this limit switch is actuated the door travels in the closed direction at a reduced speed. (Light on PLC turns **ON** when activated)

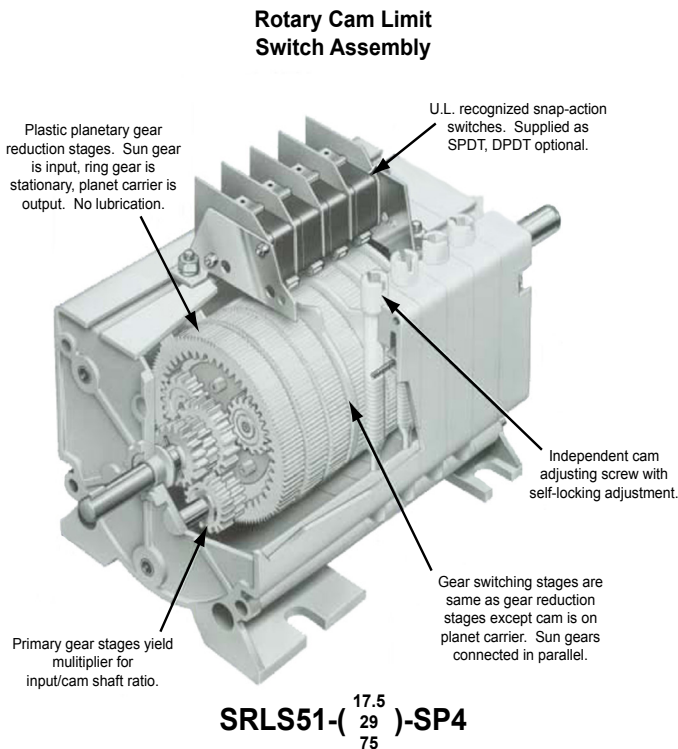

**Figure 5. Rotary Cam Limit Switch Assembly**

To adjust each individual limit switch, turn the screw adjustment for each specific limit switch. Note that depending upon the handing of the operator the cams travel from either the clockwise or counterclockwise direction to activate the appropriate snap switches.

(e) With the power turned off, manually swing the door to the full close position. Check to see LSC (limit switch close) is engaged. You can see the pointed cam engaged the limit switch roller. Adjust the limit switch by turning the limit switch adjusting screw until the cam just engages the roller. You should hear the snap switch click when it is actuated.

(f) With the power turned off, manually swing the door to the full open position. Check the see LSO (limit switch open] is engaged. You can see the cam engaged the limit switch roller. Adjust the limit switch by turning the limit switch adjusting screw until the cam just engages the roller.

(g) With the power turned off, manually swing the door to the full close position. Check to see LSCC (limit switch creep close) is engaged. You can see the extended can engage the limit switch roller. Adjust the

limit switch by turning the limit switch adjusting screw until half of the extended cam travels past the roller. When this limit switch roller is engaged the door will travel at the creep speed during the closing cycle (creep speeds are desirable during the final opening and closing positions for smooth operation).

(h) With the power still off, manually swing the door to the full open position. Check to see LSCO (limit switch creep open) is engaged. You can see the extended can engage the limit switch roller. Adjust the limit switch by turning the limit switch adjusting screw until half of the extended cam travels past the roller. When this limit switch roller is engaged adorable travel at the creep speed during the opening cycle.

(3) Turn the Electric Clutch Controller in a counterclockwise direction until "off".

(4) Turn the run-speed pot clockwise about half-way and then turn the creep-speed pot clockwise to about 1/8 of the way. Reference electrical schematic for the location of both run and creep pots. Reference **Figure 6. Safe Swinging Power Door Operating Speeds.**

**Figure 6. Safe Swinging Power Door Operating Speeds**

SAFE SWINGING POWER DOOR OPERATING SPEEDS (Time to Open or Close Measured in Seconds per ANSI A156.10 Standard)							
Door Width (Inches)	Door Weight in Lbs.						
	1,000 lbs.	2,500 lbs.	5,000 lbs.	7,500 lbs.	10,000 lbs.	12,500 lbs.	15,000 lbs.
36"	6 Sec.	10 Sec.	14 Sec.	17 Sec.	19 Sec.	22 Sec.	24 Sec.
42"	7 Sec.	11 Sec.	16 Sec.	20 Sec.	23 Sec.	25 Sec.	28 Sec.
48"	8 Sec.	13 Sec.	18 Sec.	22 Sec.	26 Sec.	29 Sec.	32 Sec.
54"	9 Sec.	15 Sec.	19 Sec.	24 Sec.	29 Sec.	32 Sec.	36 Sec.
60"	10 Sec.	16 Sec.	23 Sec.	28 Sec.	32 Sec.	36 Sec.	39 Sec.

Formula:

For Door Widths & Weights other than those listed in above table, use the below formula:

$$\text{Time to Open/Close (Sec.)} = \text{Door Width (Inches)} \times \text{SQRT}[\text{Door Weight (lbs.)}] / 188$$

**Warning:**

The door operator should NOT operate the door at a speed greater than listed in the above table.

Any attempt to operate at a faster speed will cause premature wear and damage to the operator and void the warranty.

Also, liability may occur to anyone operating the door faster than recommended if injuries occur as a result.

**(5) CHECK THE OPERATION OF THE MOTOR:**

(a) Turn the power on.

(b) Activate the door actuator, verify that the motor is turning in the correct direction.

The open relay "O" should light during the opening cycle and the close relay "C" should light during the close cycle. If they are opposite, the leads (M1 and M2) to the motor may be switched and the motor rotation will reverse.

**(6) SETTING ELECTRIC CLUTCH RESISTANCE:**

(a) Turn the Clutch Controller in a Clockwise Direction to approximately 50%.

(b) Stand clear of door and pushed open actuator button. Does the door begin the move without the clutch slipping?

- If yes, then attempt to stop the door by applying a pressure to the lead edge of the moving door once the door has reached approximately the middle of the opening. The clutch should begin to slip at and applied pressure of approximately 25 lbs. Adjust the PS90 clutch controller accordingly.

- If no, then increase clutch torque clockwise on the Clutch Controller until the door begins to move. For each adjustment be sure to stand clear of the door.

(7) Reset the run and creep speed pots in the control box to a combined equivalent speed ASP as fied in the

table on Safe Swinging Power Door Operating Speeds (table on page 4). Be sure speeds are set for smooth and safe operation of the door.

(8) Fine tune limit switches by repeating step 2 parts A through D.

(9) SETTING RUN TIMER: (refer to electric schematic)  
The run timer is an equipment safety feature which shuts off the electric motor. Set the run timer to shut off 10 seconds after a complete for close or open cycle.

(a) With the door and the full open position, depress the actuator switch to signal operator to close the door.

(b) Allow door to fully close while watching the run timer indicator light (Reference electrical schematic). The run timer light should stay on approximately 10 seconds after the door has reached the full closed position. If the run timer light is lit for more than or less than this 10 second integral, adjust the run timer pot accordingly. Turning the run timer clockwise will increase the length of time. Turning the run timer counterclockwise will decrease the length of time.

(10) OPTIONAL: Partial Open Feature

(a) Close the door to the full close position.

(b) Actuate partial open actuator, the door should open approximately half-way and shut off. Turn the partial open timer clockwise to increase the open width. Turn the partial open timer counterclockwise to decrease the open width (Refer to electrical schematic).

### 3. MAINTENANCE

#### A. GENERAL

Very little maintenance is required on the 1502.

1. Periodically check for wear on the pivot points of the arms.
2. Operators using the push arm assembly, should have the two (2) zerk fittings greased once a year depending on use.
3. Check electric clutch for proper function once a month depending upon use. Fine tune though electric clutch torque setting per installation manual (Refer to step 6, Setting Electric Clutch Resistance).
4. Verify limit switches are set correctly. Periodically check limit switches for proper adjustment.

#### 4. PARTS

##### A. TO ORDER REPLACEMENT PARTS

Order all replacement parts using the number shown on the following parts list pages.

- (1) SEND IN SERIAL NUMBER OF ELECTRIC OPERATOR.
- (2) SPECIFY the number of pieces needed.
- (3) Order by part number and name of part.
- (4) State whether to ship by freight, truck, parcel post, or air express
- (5) State whether transportation charges are to be prepaid or collect.
- (6) Give name and address of the person or company to whom the parts are to be shipped.
- (7) Give name and address of person or company to whom the invoices to be sent.

##### B. PARTS LIST

The following pages list the replacement parts which are illustrated in page 7.

Part Number	Description
1502P27	Electric Magnetic Clutch Assembly
1502P35	Adjustable Clutch Controller
1502P63-A	1/4 HP DC Gear Motor
1502-7245 (for model 1502-1)	Gearbox 5:1 Ratio
1502-7241 (for model 1502-2)	Gearbox 10:1 Ratio
1502P37	Rotary Cam Limit Switch 4:1
1502P38	35B36 Timing Sprocket
1502P40	35B36 Timing Sprocket
1502-PUSHO	Push Arm Assembly
1502-PULLO	Pull Arm Assembly



## 1502 Operator w. Cover

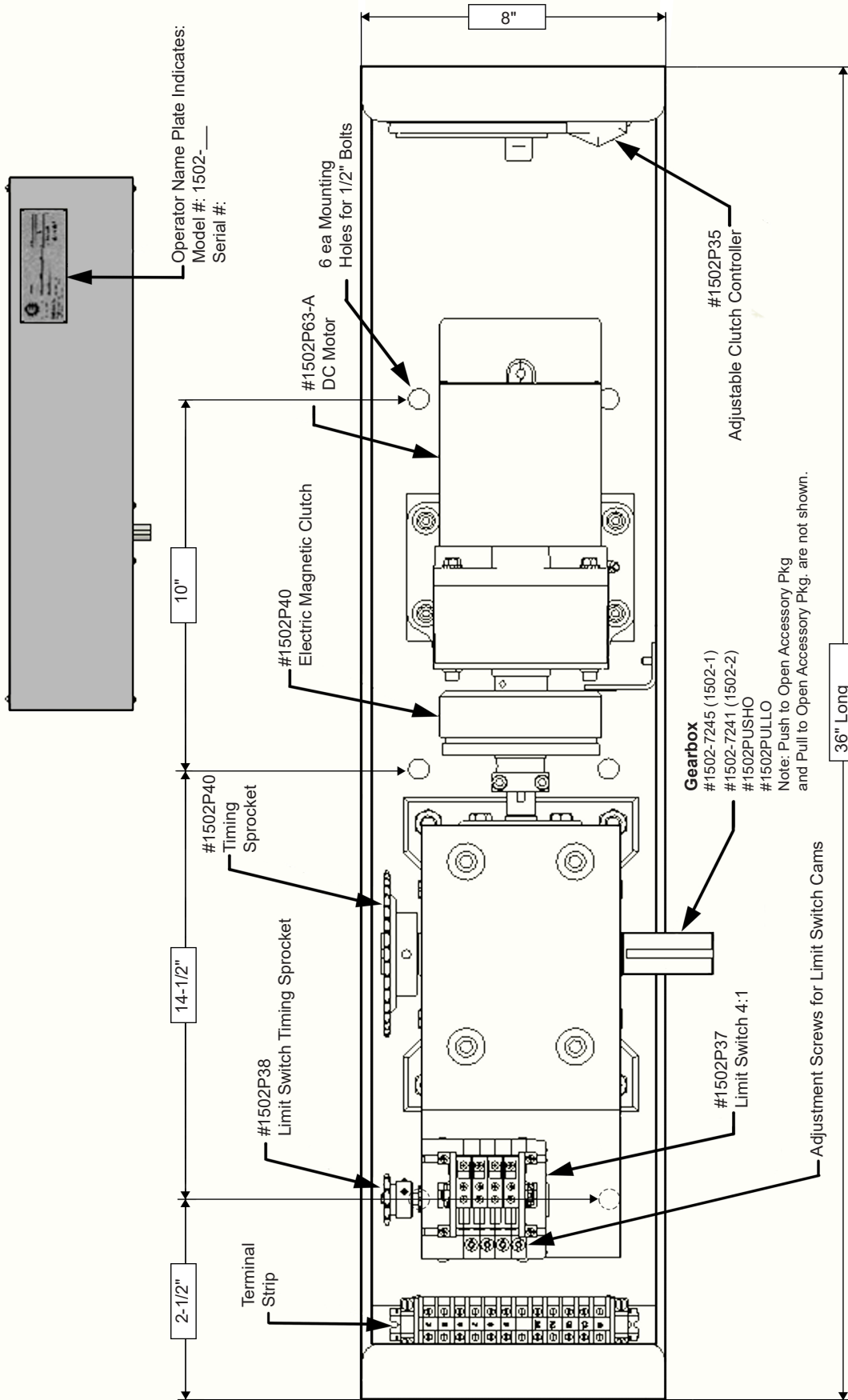

## 1502 Operator without Cover

# MAINTENANCE INFORMATION

(To Be Filled Out By User)

Operator Serial Number \_\_\_\_\_ H.P. \_\_\_\_\_

Supplied on Crown Industrial Operators Order Number \_\_\_\_\_

Power Supply \_\_\_\_\_ Volts \_\_\_\_\_ Hz \_\_\_\_\_ Phase \_\_\_\_\_

Installed At \_\_\_\_\_ Date \_\_\_\_\_

Notes \_\_\_\_\_

\_\_\_\_\_  
\_\_\_\_\_  
\_\_\_\_\_  
\_\_\_\_\_

## GUARANTEE

If, within a period of one year from date of shipment, any part of a CIO Electric "Aut-o-doR" Operator is found defective due to poor materials or workmanship, new parts will be furnished free of charge F.O.B. manufacturer's plant, providing the equipment has been given normal and proper usage, lubrication, and maintenance and is still the property of the original purchaser and/or part of the original installation. *THIS WARRANTY IS GIVEN IN LIEU OF ALL OTHER WARRANTIES, EXPRESSED OR IMPLIED, AND THE MANUFACTURER MAKES NO IMPLIED WARRANTY OF MERCHANTABILITY BEYOND THE EXPRESSED TERMS HEREOF. MANUFACTURER'S LIABILITY FOR DAMAGES, INCLUDING CONSEQUENTIAL DAMAGES RESULTING FROM ANY SUCH DEFECTIVE PRODUCT IS STRICTLY LIMITED TO THE DELIVERY OF NEW PARTS, AS SET FORTH ABOVE.*



### Crown Industrial Operators

213 Michelle Court  
So. San Francisco, CA 94080  
Phone (650) 952-5150  
Fax (650) 873-1495  
website: [www.crown-industrial.com](http://www.crown-industrial.com)